

S型传感器

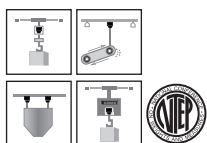
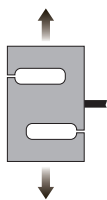

量程 Capacities

100kg, 200kg, 250kg, 500kg, 750kg, 1t, 1.5t, 2t, 2.5t, 5t, 7.5t, 10t

主要特点 Features

- S型传感器
- 通过NETP、CMC、PA认证
- 优质合金钢材质
- 安装简便、快速，稳定可靠
- 适用于材料试验机、配料秤、搅拌站、皮带秤和包装秤等

接线方式 Schematic

- 红色：+ 激励
- 黑色：- 激励
- 白色：- 信号
- 绿色：+ 信号

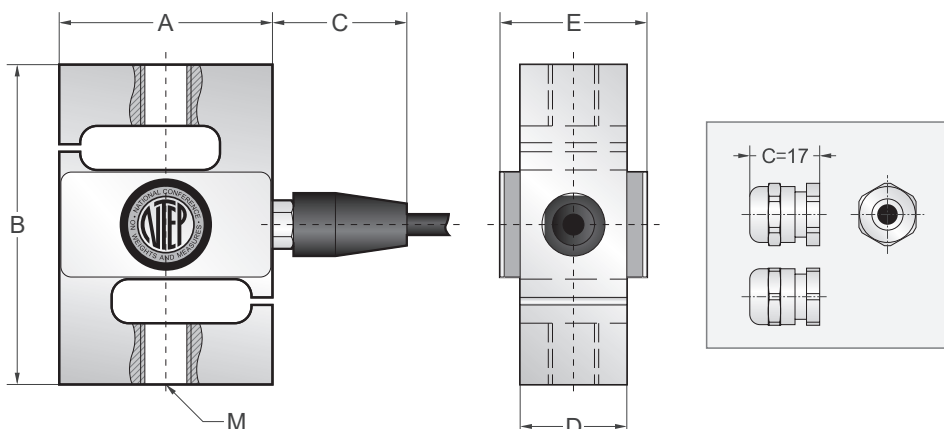
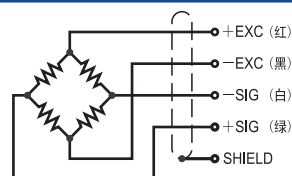

量程/Capacities		A	B	C	D	E	M
100kg	mm	50.8	76.2	32	19	28	M10X1.5
200kg-750kg	mm	50.8	76.2	32	19	28	M12×1.75
1t-1.5t	mm	50.8	76.2	32	25.4	35	M12×1.75
2t-5t	mm	76.2	108	32	25	31	M18×1.5
7.5t	mm	101.6	139.7	17	31.3	38	M24×2
10t	mm	127	177.8	17	50.4	57	M30×2

技术参数 Specifications

额定输出	3.0mV/V ±0.1%	可用温度范围	-10°C to + 70°C
零点平衡	±1% of rated output	温度补偿范围	-10°C to + 40°C
蠕变	±0.03% of rated output	安全载荷	150%
非线性	±0.03% of rated output	输入阻抗	387 ohm ± 20 ohm
滞后	±0.03% of rated output	输出阻抗	350 ohm ± 5 ohm
重复性	±0.03% of rated output	绝缘阻抗	≥5000 M ohm (50V DC)
灵敏度温漂	≤0.002% of applied output/°C	推荐激励电压	10V DC/AC
零点温度	≤0.002% of rated output/°C	最大激励电压	15V DC/AC
导线长度	6m	导线颜色	Red(+ E) Black(- E) White(- S) Green(+ S)